

DATA LINK TESTING WITH ERROR SIMULATION, SYMMETRY, AND PCM

It's not just PRN tests anymore

AP22

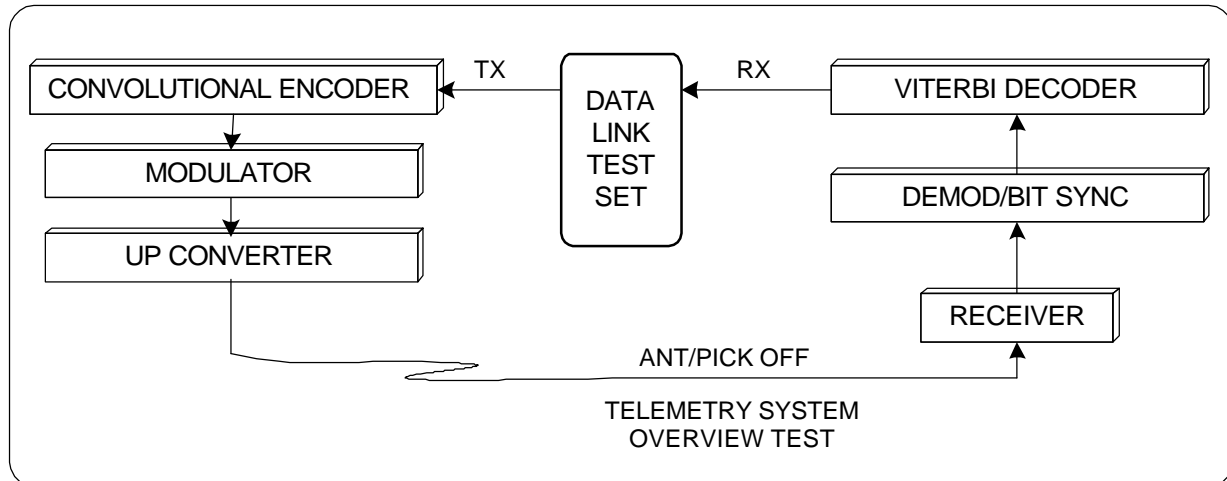

The block diagram above illustrates a typical telemetry uplink and receive station loopback test configuration involving several types of equipment. Testing of these devices can benefit from using more than a simple bit error rate tester. This Application Note identifies several unique requirements that the Model 461 Data Link Test Set addresses.

- A. **I & Q Channels.** One key feature of the 461 DLTS is the ability to configure the unit with two channels and test independent I & Q operations. Operation at the same rate can be achieved by slaving one DLTM module transmitter to the other using the external clock input (ST) function. Therefore two independent data streams can be generated with a matched clock phase and frequency. The two channels can be operated at different rates.
- B. **Error Simulations.** The 461 Transmitter provides a number of useful error insertion tools. These errors are inserted after the PRN or PCM data is generated but before the IRIG code converter.
1. **Insert One Error.** The first error type is the ability to invert a single bit per command. This is a quick way to verify that the DLTS receiver, which is showing ZERO errors, is actually connected properly and functioning when it detects and displays the single error.
 2. **Insert Known Error Rate.** This can also be used to test the DLTS receiver and display (or for testing other equipment, more on this later).

3. **Blanking.** This is the ability to force a selectable number of data bits to the all zero state AFTER any coding is applied to simulate line dropouts or measure a bit synchronizer's ability to achieve or maintain Lock during transitionless data periods. The 461 DLTS allows the number of blanked bits to be set and it provides two operating modes. The first is a 'free-run' mode where the blanks are inserted after a programmable number of normal bits. For example, blank 100 bits then output normally for 900 bits. The second mode is 'frame synchronized' where the blanking begins a selectable number of bits after the start of the PCM (or PRN) frame (or reference point) and occurs only once per frame. This is very handy when a certain field of the PCM data stream is to be erased.

- C. **Symmetry Tests.** Data symmetry is the ratio of data '1' bits to data '0' bits. PRN data begins with symmetry of 50%, an equal number of 1's and 0's in a given time frame. Thus if a link has a biasing problem, for example if the receiver discriminator is offset from the transmitted frequency, there may be a greater tendency to change 0's into 1's or vice versa.

The 461 DLTS provides a count of 1's in error and a symmetry calculation to support this kind of investigation. With random errors, the symmetry should show 50% with PRN data and the evaluation is straightforward. While displaying the number of bit errors and 1's in error, FREEZE the 461 display updates and compare these numbers. Normally the 1's in error should be about half of the total bit errors. Any bias will become very apparent. An alternative method is to display the calculated SYMMETRY value, which is constantly updated by operating the 461 receiver in the periodic mode (vs. accumulate). The display will be updated with the results of tests conducted every 10^6 bits for example. This can allow the operator to make adjustments in the link transmission and reception equipment while monitoring its effect on the symmetry.

Many times, a link may test very good when using PRN data due to the large number of data transitions and the 50% data symmetry, only to have problems when the actual PCM mission data begins to flow due to A.C. coupling. Using the 461 DLTS' PCM data mode and programming a frame format that more nearly resembles the data to be encountered can detect this. The unit allows the data word values to be specified so that fewer transitions and the data symmetry characteristics can be accurately modeled.

- D. **Pulse Coded Modulation.** Using PCM data allows more of the equipment in the link to be verified in addition to just the serial data link functions shown. Frame synchronizers, computer ingests and display systems, strip chart recorders, etc. can all be tested (see subsequent App. Notes). The error insertion capability will allow that equipment's performance under noisy path conditions to be evaluated. For example, how will random errors in the data affect a strip chart display?