

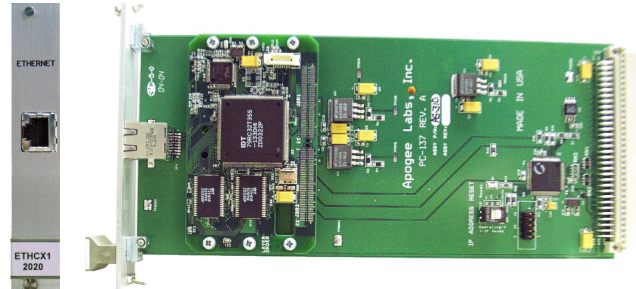

2020 ETHCX1 ETHERNET CONTROLLER MODULE



1. FEATURES

- Single Slot Module
- Automatically replaces existing remote control
- Complies with 10/100 base-T Ethernet operation
- Fully supports Apogee Labs standard full duplex remote control protocol
- Switch-enabled automatic reset of default IP address setting

2. OVERVIEW

The Model 2020 ETHCX1 module provides a remote control capability for an AL4300 Series chassis using an Ethernet 10/100 Base-T link. This ETHCX1 supports all the remote control commands listed in the individual manuals for the AL4300 modules installed in the chassis. These commands are ASCII coded control and status interrogation commands, each of which are individually Acknowledged. This is designated as the Network Native ASCII Transfer or NNAT remote control mode.

The control processor on the ETHCX1 receives incoming data from the Ethernet. Completed commands received are then sent to the Front Panel Controller of the chassis via the internal ALISDT bus. The Front Panel Controller in turn directs the data to the selected module. This target module processes the command and provides a response back to the Front Panel Controller, which forwards this to the ETHCX1. The ETHCX1 holds the response until interrogated from the Ethernet.

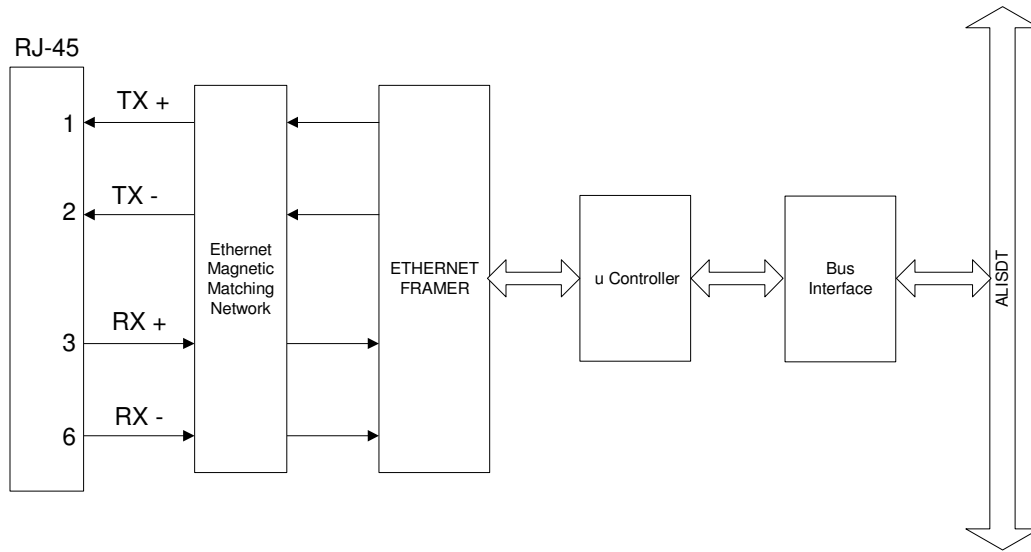

Figure 1 - ETHCX1 Simplified Block Diagram

3. SPECIFICATIONS

- Compliant with IEEE 802.3 / Ethernet V.2
- 10/100 Base-T operation
- RJ-45 connector
- Full Duplex Operation
- Supports TCP/IP, UDP and Apogee Labs NNAT
- Occupies one AL4300 chassis slot

Apogee Labs, Inc. sells its products by description only. Apogee Labs, Inc. reserves the right to make changes in circuit design, software, hardware and/or specifications at any time without notice. Although Apogee Labs, Inc. believes that the information provided is current and accurate, Apogee Labs, Inc. does not assume any responsibility or liability for the use of any product described. It is the responsibility of the user to determine appropriate use of the product in any given application.