

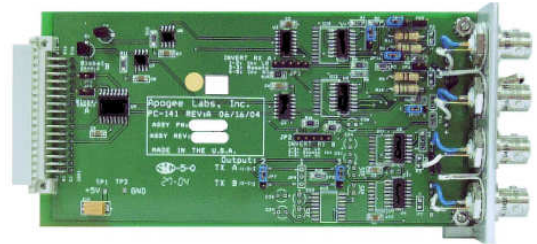

MODEL IOC210
RS-422 TO RS-422
CONVERTER MODULE
WITH
BYPASS SWITCH



REAR VIEW



SIDE VIEW

1. FEATURES

- **Two Independent RS-422 Level Inputs**
- **Two Independent RS-422 Level Outputs**
- **Selectable Input Termination (75 Ohm/124 Ohm)**
- **Independent Output Polarity Selection**
- **Switch to Bypass Internal Electronics and Input Termination**
- **Input Activity LED on Front Panel for each Channel**
- **Drives Daisy Chain Bus and Global Bus**
- **High Current Outputs Meet ANSI TIA/EIA-422-B Requirement**

2. OVERVIEW

The IOC210 Pluggable Interface Module (PIM) accepts two RS-422 Level input signals and produces two RS-422 level output signals. The module provides input termination, signal inversion and buffering. The signal polarity of each channel is independently controlled. A Bypass switch for each channel allows the user to bypass the input signal directly to the output connector for each channel. Selecting the Active position engages the signal termination, polarity control and buffering circuitry. Figure 1 highlights these features. The IOC210 presents all of its signal interface connections on Triaxial connectors. Signaling rates up to and including 20M bps are accommodated. Installed in an AL2073 chassis, this module may be connected to the daisy chain bus and the global bus. This feature enables the user to create multiple copies of the 2 input signals from this module. The IOC210 requires 2 slots of the 14 available slots in an AL2073 chassis.

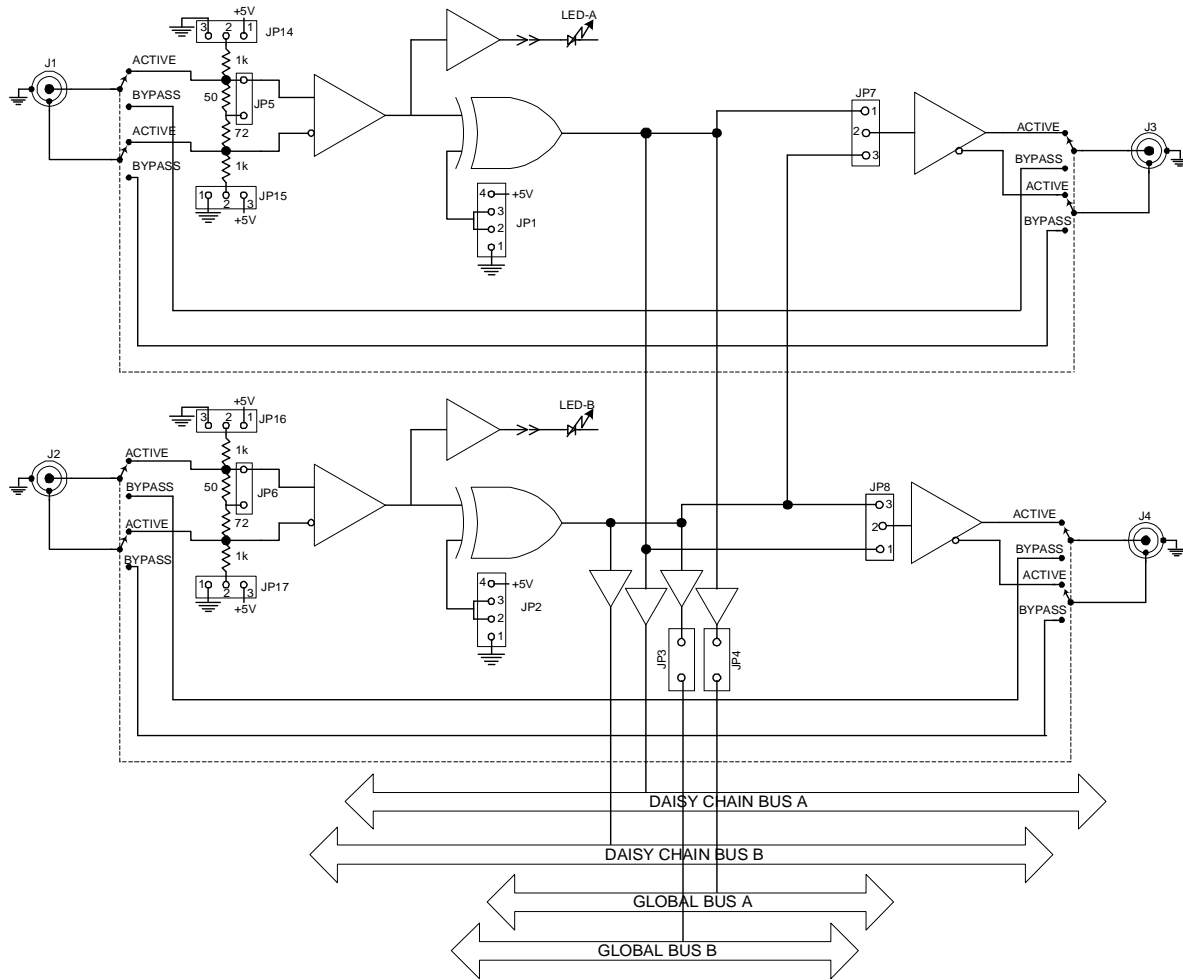

Figure 1: Model IOC210 Block Diagram

3. SPECIFICATIONS

GENERAL

2 Independent channels
 2 Slot Module (3" x 6" x 1.8")
 Model 2073 Pluggable Interface Module

INPUT

RS-422 Level Inputs
 TRIAX Connectors (Trompeter Part No. BJ770)
 75/124-ohm selectable termination

OUTPUT

RS-422 Level Outputs
 Triax connectors
 Switch Selectable (Active or Bypass)

4. APPLICATION

The IOC210 is used to terminate and drive 2 RS-422 signals. It incorporates a switch allowing the user to bypass the termination and electronics depending on the requirement. Each signal can be inverted independently.

Typical application of the IOC210 is a distribution application where the daisy chain bus or global bus is used to distribute multiple copies of one or both input signals.

When mated with the IOC205, the IOC210 acts as the input card in a 1 input to 3 output distribution matrix.

This module can also be plugged into Apogee Models:

2907 and 2908: Data Acquisition Mux/Demux

6801: 5 Channel BERT Operation

6804: Multi Channel Clock Recovery

Apogee Labs Inc. products are sold by description only. Apogee Labs Inc. reserves the right to make changes in circuit design, software, hardware and/or specifications at any time without notice. Although Apogee Labs Inc. believes that the information provided is current and accurate, Apogee Labs Inc. does not assume any responsibility or liability for the use of any product described. It is the responsibility of the user to determine appropriate use of the product in any given application.